

those nucleotide combinations which result in Watson-Crick types of hydrogen bonds were excluded. Thus, in repeating dinucleotide structure, syntheses were undertaken of the homologous series of deoxypolynucleotides containing the following dinucleotides in repeating sequence: thymidyldeoxycytidine (two pyrimidines), deoxyadenyldeoxyguanosine (two purines), thymidyldeoxyguanosine (two keto bases), and deoxycytidyldeoxyadenosine (two amino bases). In the series of deoxypolynucleotides with repeating trinucleotide sequences, the syntheses of the repeating sequences thymidylthymidyldeoxycytidine and thymidylthymidyldeoxyinosine were undertaken first. Subsequent to these, hexanucleotides containing the complementary triplets deoxyguanylyldeoxyadenyldeoxyadenosine and deoxycytidyldeoxyadenyldeoxyadenosine were synthesized.

Four accompanying papers²⁶⁻²⁹ describe the synthetic work on the above series of deoxyribopolynucleotides. So far as the enzymatic studies with the resulting polynucleotides are concerned, all of the major expectations have already been realized. Thus, the DNA polymerase utilizes a mixture of the two decanucleotides, containing the repeating sequences thymidyldeoxycytidine and deoxyguanylyldeoxyadenosine, as

deoxyadenylate and thymidylate units as template for RNA polymerase, fails to stimulate amino acid incorporation (unpublished work of Professor S. Ochoa and co-workers and of Dr. S. Nishimura in this laboratory).

(26) E. Ohtsuka, M. W. Moon, and H. G. Khorana, *J. Am. Chem. Soc.*, **87**, 2956 (1965).

(27) T. M. Jacob and H. G. Khorana, *ibid.*, **87**, 2971 (1965).

(28) S. A. Narang and H. G. Khorana, *ibid.*, **87**, 2981 (1965).

(29) S. A. Narang, T. M. Jacob, and H. G. Khorana, *ibid.*, **87**, 2988 (1965).

the templates, and, in the presence of the 5'-triphosphates of the four deoxynucleosides brings about the extensive synthesis of a high molecular weight DNA-like polymer containing alternating deoxycytidylate and thymidylate units in one strand and deoxyguanylate and deoxyadenylate units in the complementary strand.³⁰ Analogously, the synthesis of another two-stranded DNA-like polymer, containing deoxyguanylate and thymidylate units in alternating sequence and deoxycytidylate and deoxyadenylate units in alternating sequence in the two complementary strands, is brought about in response to the two decanucleotides containing the above repeating dinucleotide sequences.³¹ High molecular weight ribopolynucleotide of repeating di- and trinucleotide sequences have been prepared by using the short-chain synthetic deoxyribopolynucleotides as templates for DNA-dependent RNA polymerase.³² Ribopolynucleotides containing repeating dinucleotide sequences have also been prepared by the use of DNA-like polymers mentioned above as templates for the RNA polymerase. Finally, the synthesis of homopeptides and copeptides as directed by ribopolynucleotides containing, respectively, repeating trinucleotide and dinucleotide sequences has also been demonstrated.³³⁻³⁵

(30) C. Byrd, E. Ohtsuka, M. W. Moon, and H. G. Khorana, *Proc. Natl. Acad. Sci. U. S.*, **53**, 79 (1965).

(31) R. D. Wells, E. Ohtsuka, and H. G. Khorana, unpublished work.
(32) S. Nishimura, T. M. Jacob, and H. G. Khorana, *Proc. Natl. Acad. Sci. U. S.*, **52**, 1494 (1964), and unpublished work of Dr. S. Nishimura.

(33) S. Nishimura, D. S. Jones, R. D. Wells, T. M. Jacob, and H. G. Khorana, *Federation Proc.*, **24**, 409 (1965).

(34) S. Nishimura, D. S. Jones, E. Ohtsuka, H. Hayatsu, T. M. Jacob, and H. G. Khorana, *J. Mol. Biol.*, in press.

(35) S. Nishimura, D. S. Jones, and H. G. Khorana, *ibid.*, in press

Studies on Polynucleotides. XLIII.¹ The Synthesis of Deoxyribopolynucleotides Containing Repeating Dinucleotide Sequences^{2,3}

E. Ohtsuka, M. W. Moon, and H. G. Khorana

Contribution from the Institute for Enzyme Research of the University of Wisconsin, Madison, Wisconsin. Received March 22, 1965

The synthesis and characterization of four series of homologous deoxyribopolynucleotides, up to the dodecanucleotides, containing the following dinucleotides in repeating sequences is described: thymidyldeoxycytidylate, thymidyldeoxyguanylate, deoxyadenyldeoxyguanylate, deoxycytidyldeoxyadenylate. The general method of synthesis involved the polymerization of suitably protected dinucleotides by reaction with di-

cyclohexylcarbodiimide followed by removal of the protecting groups and separation by a combination of anion exchange and paper chromatography. The nature of side products which were encountered is discussed.

(1) Paper XLII: H. G. Khorana, T. M. Jacob, M. W. Moon, S. A. Narang, and E. Ohtsuka, *J. Am. Chem. Soc.*, **87**, 2954 (1965).

(2) For leading references to previous papers which deal directly with the synthesis of deoxyribopolynucleotides containing specific sequences, see ref. 1.

(3) This work has been supported by grants from the National Science Foundation (Grant No. GB-976), the National Cancer Institute of the National Institutes of Health (Grant No. CA-05178), and the Life Insurance Medical Research Fund (Grant No. G-62-54).

The synthesis of deoxyribopolynucleotides containing repeating di- and trinucleotide sequences is of interest in the study of the amino acid code, and a review of the major objectives of synthetic work has been given in the preceding paper.¹ The present paper records the synthesis and characterization of several series of homologous short-chain deoxyribopolynucleotides containing the repeating dinucleotide sequences thymidyldeoxycytidine, thymidyldeoxyguanosine, deoxyadenyldeoxyguanosine, and deoxycytidyldeoxyadeno-

Table I. Paper Chromatography and Paper Electrophoresis of Mono- and Dinucleotides and Derivatives

Compounds	R_f in solvent				Electrophoretic mobility ^a	
	A	C	D	E	pH 7.1	pH 2.7
β -Cyanoethyl thymidine 5'-phosphate		0.65			0.58 (pT)	
5'-O-Phosphorylthymidyl-(3'→5')-N ⁶ -anisoyldeoxycytidine	0.11	0.43			0.86 (pT)	0.78 (pT)
5'-O-Phosphorylthymidyl-(3'→5')-deoxycytidine	0.03	0.17			1.07 (pT)	0.68 (pT)
5'-O-Phosphorylthymidyl-(3'→5')-N ⁶ -anisoyl-3'-O-acetyldeoxycytidine		0.52				
β -Cyanoethyl N-benzoyldeoxyadenosine 5'-phosphate		0.80			0.50 (d-pA ^{Ba})	
5'-O-Phosphoryl-N-benzoyldeoxyadenyl-(3'→5')-N-acetyldeoxyguanosine		0.28				
5'-O-Phosphoryldeoxyadenyl-(3'→5')-deoxyguanosine		0.12	0.26			
5'-O-Phosphoryl-N ⁶ -anisoyldeoxycytidyl-(3'→5')-N ⁶ -benzoyldeoxyadenosine		0.40		0.78	0.74 (d-pC)	1.43 (d-pC ^{An})
5'-O-Phosphoryldeoxycytidyl-(3'→5')-deoxyadenosine		0.09		0.61	1.08 (d-pA)	
5'-O-Phosphoryl-N ⁶ -anisoyldeoxycytidyl-(3'→5')-N ⁶ -benzoyl-3'-O-acetyldeoxyadenosine		0.49				
5'-O-Phosphorylthymidyl-(3'→5')-N-acetyldeoxyguanosine		0.25				
5'-O-Phosphorylthymidyl-(3'→5')-N-3'-O-diacetyldeoxyguanosine		0.35				

^a The electrophoretic mobilities are relative to those of the compounds given in parenthesis following mobility.

sine.⁴ Three accompanying papers describe the syntheses of deoxyribopolynucleotides containing repeating trinucleotide sequences.⁵⁻⁷

Protected Dinucleotides. Previously the synthesis of deoxyribopolynucleotides containing alternating deoxycytidylate and deoxyguanylate units⁸ and of deoxyribopolynucleotides containing alternating thymidylate and deoxyadenylate units⁹ has been reported. The approach used involved the polymerization of suitably protected dinucleotides. The same general approach has been used in the work described in the present paper. The synthesis of all of the desired protected dinucleotides was accomplished by the route illustrated in the formulas I-VI.

β -Cyanoethyl esters of mononucleotides (I) were prepared by the reaction of the appropriate mononucleotide with an excess of hydroacrylonitrile in the presence of dicyclohexylcarbodiimide (DCC).^{8,9} During this reaction some of the neutral ester (dicyanoethyl ester) is also obtained. In the case of β -cyanoethyl thymidine 5'-phosphate the neutral ester could be selectively hydrolyzed by keeping an aqueous pyridine solution at pH 9,¹⁰ and the desired product was isolated in 75% yield simply by precipitation from ether. β -Cyanoethyl N-benzoyldeoxyadenosine 5'-phosphate, the only member of this class of derivatives whose synthesis has not been recorded previously, could not be freed from the neutral ester by selective hydrolysis of the latter at pH 9. Exposure of the nucleotide at this pH caused partial loss of the N-benzoyl group and, to avoid this

(4) A brief report of a part of this work has previously been made: T. M. Jacob, E. Ohtsuka, M. W. Moon, S. A. Narang, and H. G. Khorana, *Federation Proc.*, **23**, 531 (1964).

(5) T. M. Jacob and H. G. Khorana, *J. Am. Chem. Soc.*, **87**, 2971 (1965).

(6) S. A. Narang and H. G. Khorana, *ibid.*, **87**, 2981 (1965).

(7) S. A. Narang, T. M. Jacob, and H. G. Khorana, *ibid.*, **87**, 2988 (1965).

(8) H. Schaller and H. G. Khorana, *ibid.*, **85**, 3841 (1963).

(9) G. Weimann, H. Schaller, and H. G. Khorana, *ibid.*, **85**, 3835 (1963).

(10) Cf. H. Schaller and H. G. Khorana, *ibid.*, **85**, 3828 (1963).

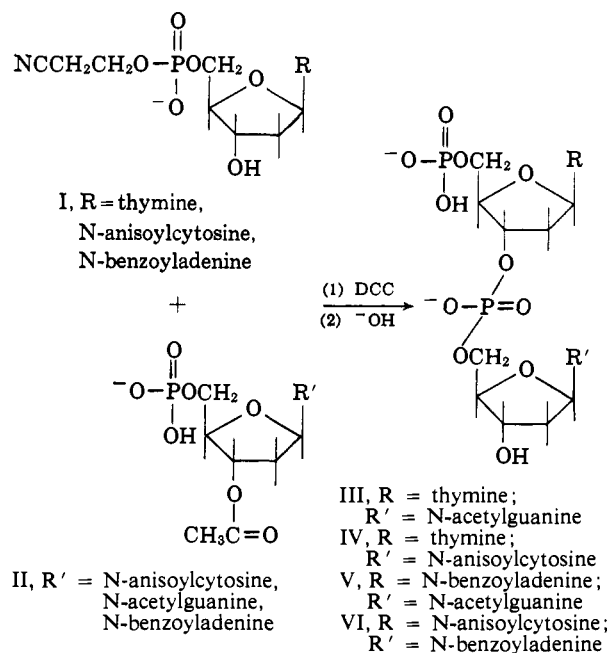

side reaction, chromatography on a DEAE-cellulose column was used to purify the β -cyanoethyl ester. The isolated yield of the desired product was 62%.

Condensation of these protected derivatives with the appropriate 3'-O-acetyl N-protected nucleoside 5'-phosphates,⁸⁻¹⁰ all of which are available from previous work, in the presence of DCC, and subsequent purification by anion-exchange chromatography gave the protected dinucleotides III-VI. The isolated yields using approximately equivalent amounts of the two components were 45-48%. All the protected mono- and dinucleotide derivatives were fully characterized and checked for homogeneity by paper chromatography and paper electrophoresis (Table I).

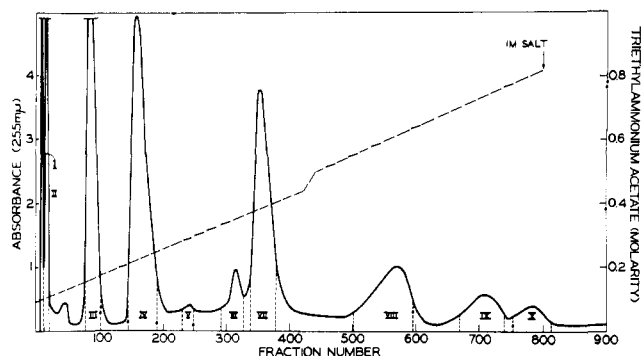

Figure 1. Chromatography of deoxyribopolynucleotides containing alternating thymidylate and deoxyguanylate units on a DEAE-cellulose (acetate) column (50 × 1.1 cm.) pre-equilibrated with 50% ethyl alcohol. Elution was carried out using a linear salt gradient of triethylammonium acetate (pH 6.5) in 50% ethyl alcohol (1.5 l. of 0.1 M salt in the mixing vessel and an equal volume of 0.5 M salt in the reservoir). After the total solution had passed through, the mixing vessel was supplied with 1 l. of 0.5 M triethylammonium acetate (50% ethyl alcohol) and the reservoir with 1 l. of the same salt (1.0 M) in 50% ethyl alcohol. Fractions of about 4.6 ml. were collected every 15 min.; ----- salt gradient; pooling points. For the identification of peaks, see Table II.

Deoxyribopolynucleotides Containing Alternating Thymidylate and Deoxyguanylate Units. For the polymerization reaction a mixture of the pyridinium salt of the dinucleotide d-pTpG^{Ac} (III) and its 3'-O-acetyl derivative (d-pTpG^{Ac}OAc)¹¹ was used. The reaction with the condensing agent DCC was started using a mixture of dimethylformamide and pyridine as the solvent, but most of the latter was soon removed and the gummy mixture was allowed to stand for a period of seven days at room temperature. The work-up included (1) successive treatments with acetic anhydride-pyridine and benzoic anhydride-pyridine to cleave the residual pyrophosphate bonds,^{12,13} and (2) an ammoniacal treatment to remove the protecting groups. Chromatography of a portion of the polymeric mixture on a DEAE-cellulose (acetate form) column using triethylammonium acetate in 50% ethyl alcohol as the eluent (*cf.* ref. 5) gave the elution pattern shown in Figure 1. The distribution of the nucleotidic material in different peaks and the identification of the different peaks are given in Table II.

Thus, cyclo-d-pTpG¹⁴ was present in peak III and the next homolog, cyclo-d-pTpGpTpG,¹⁴ was present in peak VI (Figure 1). Peak VII contained pure tetra-

(11) The basic system of abbreviations used for polynucleotides and their protected derivatives is as has been used in previous papers in this series (see, *e.g.*, ref. 8) and is in current use in *J. Biol. Chem.* Thus, the single letters A, T, C, and G represent the nucleosides of respectively adenine, thymine, cytosine, and guanine. The letter "p" to the left of the nucleoside initial indicates a 5'-phosphomonoester group and the same letter to the right indicates a 3'-phosphomonoester group. Thus, in going from the left to the right the polynucleotide chain is specified in the C_{3'}-C_{5'} direction. The protecting groups on the purine or pyrimidine rings are designated by two-letter abbreviations added as superscripts after the nucleoside initial: thus A^{Bz} for N-benzoyldeoxyadenosine, C^{An} for N-anisoyldeoxycytidine, G^{Ac} for N-acetyldeoxyguanosine. The acetyl group at the 3'-hydroxyl group of a nucleoside is shown by -OAc added after the nucleoside initial: thus d-pTpG^{Ac}-OAc for the dinucleotide, 5'-O-phosphorylthymidyl(3'→5')-N^{3'}-O-diacetyldeoxyguanosine.

(12) H. G. Khorana and J. P. Vizsolyi, *J. Am. Chem. Soc.*, **81**, 4660 (1959).

(13) M. W. Moon and H. G. Khorana, *ibid.*, forthcoming paper.

(14) Abbreviation for the cyclic oligonucleotides in which a macrocyclic ring is formed by the esterification of the phosphomonoester group at one terminus of an oligonucleotide with the hydroxyl group at the opposite terminus.

Table II. Chromatography of Deoxyribopolynucleotides Containing Alternating Thymidylate and Deoxyguanylate Units on a DEAE-Cellulose (Acetate) Column^a

Peaks	Fraction no.	Total O.D. at 255 mμ	Poly-mers, %	Identification remarks
I	10-14	72	3.3	Unidentified
II	15-22	110		Mainly benzoic acid
III	76-100	464	21.4	Cyclo-d-pTpG
IV	144-190	606	28.0	d-pTpG
V	234-246	21	1.0	Unidentified
VI	292-328	97	4.5	Mainly cyclo-d-pTpGpTpG
VII	338-378	530	24.5	d-pTpGpTpG
VIII	502-596	238	11.0	d-pT(pGpT) ₂ pG + side product ^b
IX	671-740	115	5.3	d-pT(pGpT) ₃ pG + side product ^b
X	753-812	55	2.5	d-pT(pGpT) ₄ pG + side product ^b

^a For details of procedure and elution pattern see Figure 1.

^b This side product was shown to carry a phosphomonoester group at both ends. For details of structure see discussion in text.

nucleotide d-pTpGpTpG, while the hexanucleotide d-pTpGpTpGpTpG was the major (88%) component of peak VIII, the two minor contaminants being separated after phosphomonoesterase treatment by further chromatography in solvent D. The *R_f* values of the various deoxyribopolynucleotides of this series in two solvents are given in Table III while the results of enzymic degradation of the tetra- and hexanucleotides after removal of the 5'-phosphomonoester group are included in Table IV.

Table III. Paper Chromatography of Oligonucleotides Containing Thymidine and Deoxyguanosine

Compound	—Solvent D—		—Solvent F—	
	<i>R_f</i>	<i>R_f</i> relative to d-pTpGpTpG	<i>R_f</i>	<i>R_f</i> relative to d-pTpGpTpG
Oligonucleotides bearing 5'-phosphate end groups				
d-pTpG	0.67		0.78	
d-pTpGpTpG	0.39	1	0.45	1
d-pT(pGpT) ₂ pG		0.45		0.58
d-pT(pGpT) ₃ pG		0.19		0.33
d-pT(pGpT) ₄ pG		0.08		0.19
d-pT(pGpT) ₅ pG		0.04		0.08
Oligonucleotides lacking phosphomonoester end groups				
d-TpG	1.21		0.86	
Cyclo-d-pTpG	0.91		0.75	
d-TpGpTpG		1.80		1.56
Cyclo-d-pTpGpTpG	0.42		0.47	
d-T(pGpT) ₂ pG		0.92		0.88
d-T(pGpT) ₃ pG		0.49		0.43
d-T(pGpT) ₄ pG		0.20		0.32
d-T(pGpT) ₅ pG		...		0.14

An alternative procedure for the fractionation of the polymeric mixture was used for the isolation and purification of the higher members of the series which were present only in small amounts. This technique involved initial separation of the mixture by preparative paper chromatography and subsequent anion-exchange chromatography in the presence of 7 M urea¹⁵ of the fraction containing octa- and higher polynucleotides. The conditions used and the elution pattern obtained

(15) G. M. Tener and N. Tomlinson, *J. Am. Chem. Soc.*, **84**, 2644 (1962); *Biochemistry*, **2**, 697 (1963).

Table IV. Spleen Phosphodiesterase Degradation of Deoxypolynucleotides Containing Alternating Thymidylate and Deoxyguanylate Units and Lacking 5'-Phosphate End Groups^a

Compound	d-G		Tp		d-Gp		Ratio	
	O.D./ml.	mμmoles ^b	O.D./ml.	mμmoles ^c	O.D./ml.	mμmoles ^b	Found	Theor.
TpGpTpG ^d	0.222	16.2	0.335	34.9	0.242	17.6	1:2.16:1.09	1:2:1
Tp(GpTp) ₂ G ^e	0.301	22.0	0.678	70.6	0.636	46.5	1:3.21:2.11	1:3:2
Tp(GpTp) ₃ G ^e	0.317	23.1	0.954	99.4	0.968	71.6	1:4.30:3.10	1:4:3
Tp(GpTp) ₄ G ^d	0.276	20.1	1.010	105	1.120	85.5	1:5.24:4.17	1:5:4

^a The incubation was at 37° for 6 hr. under the standard condition. The total incubation mixtures were analyzed by paper chromatography in solvent C. The spots corresponding to d-G, Tp, and d-Gp were eluted with 3 ml. of 0.05 M phosphate buffer (pH 7.0) along with appropriate blanks. ^b Using a figure of 13,700 for ϵ_{max} at 252 mμ for d-G and d-Gp at pH 7.0. ^c Using a figure of 9600 for ϵ_{max} at 267 mμ for Tp at pH 7.0. ^d These products were completely degraded by purified venom diesterase to the expected products, T, pT, and d-pG. ^e These products were almost completely degraded by purified snake venom diesterase to the expected products.

are shown in Figure 2 and the distribution of the nucleotidic material in different peaks is shown in Table V. Peak IV of Figure 2 contained pure octanucleotide d-pTpGpTpGpTpGpTpG, while peaks VI and VIII contained, respectively, the decanucleotide d-pT(pGpT)₄pG and the dodecanucleotide d-pT(pGpT)₅pG as the major products (Table V). Further

purification of these two polynucleotides was accomplished by enzymic removal of the phosphomonoester groups followed by paper chromatography. The purified products were checked for purity by paper chromatography in two solvents (Table III) and the decanucleotide lacking the phosphomonoester group, d-T(pGpT)₄pG, was also characterized by degradation with the splenic phosphodiesterase (Table IV).

Table V. Chromatography of Deoxyribopolynucleotides (Octanucleotide and Higher) Containing Alternating Thymidylate and Deoxyguanylate Units^a

Peaks	Fractions pooled and desalted	Total O.D. at 256 mμ	Total eluted, %	Identification remarks	Purity, %
I	10-20	32	5.9	Unidentified	
II	21-35	43	8.5	Compounds lower than octanucleotide	
III	36-45	72	14.3	Side product ^b	
IV	46-60	142	28.2	d-pT(pGpT) ₃ -pG	Essentially 100
V	71-90	49	9.7	Side product ^b	
VI	91-110	50	9.9	d-pT(pGpT) ₄ -pG	83
VII	122-151	30	6.0	Side product ^b	
VIII	152-181	8	1.6	d-pT(pGpT) ₅ -pG	>90
IX	245-260	56	11.1	2 M fraction	

^a The chromatography was on a DEAE-cellulose (chloride) column in the presence of 7 M urea. The elution pattern is given in Figure 2. For details of procedure see text. ^b All these side products belong to the class of compounds bearing phosphomonoester groups at both ends.

Table VI. Yields of Deoxypolynucleotides Containing Alternating Thymidylate and Deoxycytidylate Units^a

Compound	A ^b	B ^{c,d}
Cyclo-d-pTpC	31.7	64
d-pTpC	18.9	7.9
Cyclo-d-pTpCpTpC	3.4	8.4
d-pTpCpTpC	16.4	5.5
d-pT(pCpT) ₂ pC	10.0	3.9
d-pT(pCpT) ₃ pC and higher homologs	19.5	9.7

^a The separation of the total polymeric mixture was by preparative paper chromatography in solvent D (see text). ^b Polymerization of d-pTpC^{An} + d-pTpC^{An}-OAc; percentage of crude products. ^c Polymerization of d-pTpC^{An}; percentage of crude products. ^d The dinucleotide was polymerized using similar reaction conditions to those used for the polymerization of the mixture of d-pTpC^{An} and d-pTpC^{An}-OAc as described in text.

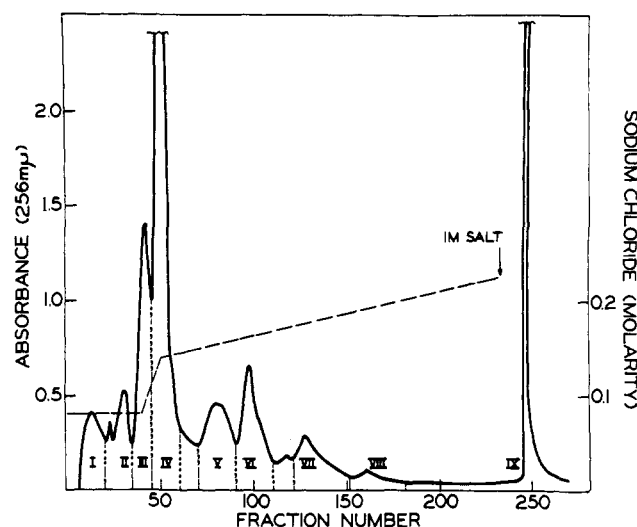

Figure 2. Chromatography of deoxyribopolynucleotides (octanucleotide and higher) containing alternating thymidylate and deoxyguanylate units on a DEAE-cellulose (chloride) column (60 × 1.5 cm.). Elution was carried out using a linear salt gradient, 1.7 l. of 0.18 M sodium chloride in the mixing vessel and an equal volume of 0.28 M sodium chloride in the reservoir, with both solutions containing 7 M urea and 50 ml. of 0.1 M sodium acetate (pH 4.8). Fractions of about 8 ml. were collected every 30 min.; ----- salt gradient; - - - - - pooling points. For the identification of peaks, see Table V.

The nature of the side products encountered in the polymeric mixture is discussed later.

Deoxyribopolynucleotides Containing Alternating Thymidylate and Deoxycytidylate Units. For polymerization a mixture of the protected dinucleotide, d-pTpC^{An} (IV), and its acetylated derivative, d-pTpC^{An}-OAc, was used because, as expected, when the latter component was omitted, the cyclic dinucleotide was produced in an overwhelming amount (compare columns A and B of Table VI). The method of polymerization and the work-up of the reaction mixture were essentially as described for the preceding series of deoxyribopolynucleotides.

Table VII. Chromatography of Higher Deoxypolynucleotides Containing Alternating Thymidylate and Deoxycytidylate Units^a

Peak no.	Fractions pooled and desalted	Total O.D. at 270 m μ	Total eluted, %	Identification	Purity ^b
I	140-167	399	34.7	d-pT(pCpT) ₈ pC	64
II	168-210	160	13.9	d-pTpCpTpCpTpC + isomer, 3'→3' compound ^c	55 45
III	256-290	133	11.5	d-pT(pCpT) ₄ pC	51
IV	291-320	93	8.1	d-pT(pCpT) ₂ pCpTpC + isomer, 3'→3' compound ^c	55 45
V	371-390	42	3.7	d-pT(pCpT) ₃ pC	>90
VI	406-435	62	5.4	Side product ^c	
VII	456-495	40	3.5	d-pT(pCpT) ₂ pC	>90
VIII	509-550	39	3.4	Side product ^c	
IX	551-609	39	3.4	d-pT(pCpT) ₁ pC	~80
X	610-612	81	7.0	2 M fraction	

^a The total polymeric mixture contained the octanucleotide and higher members of the series. Chromatography was on a DEAE-cellulose (chloride) column in the presence of 7 M urea. For elution pattern see Figure 3 and for details see text. ^b As judged by treatment with bacterial alkaline phosphatase followed by paper chromatography of the products. ^c See Table XVI.

Separation of the polymeric mixture by preparative paper chromatography gave a series of well-resolved bands corresponding to the lower homologs. The distribution of the nucleotidic material in the different bands and their approximate composition is shown in Table VI. The bands corresponding to cyclo-d-pTpC, d-pTpC, and cyclo-d-pTpCpTpC contained essentially pure compounds. However, the bands corresponding to d-pTpCpTpC and the hexanucleotide d-pTpCpTpCpTpC contained impurities, which were separated by incubation of the total material in each band with bacterial alkaline phosphatase and subsequent paper chromatography.

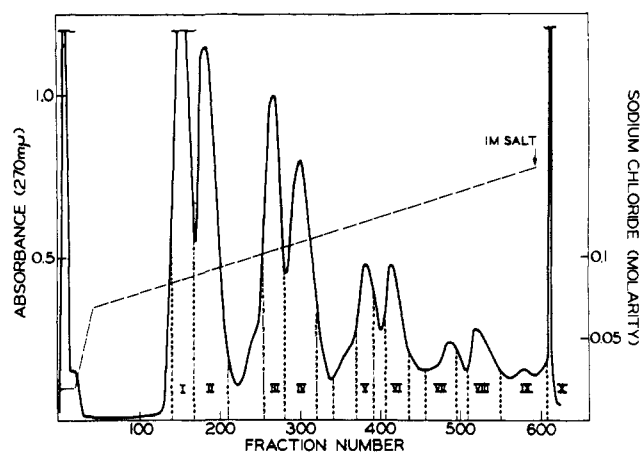

Figure 3. Chromatography of deoxyribopolynucleotides (octanucleotide and higher) containing alternating thymidylate and deoxycytidylate units on a DEAE-cellulose (chloride) column (54 × 1.5 cm.) pre-equilibrated with 0.02 M sodium chloride + 7 M urea. Elution was carried out with a linear salt gradient, 1.8 l. of 0.005 M hydrochloric acid + 0.07 M sodium chloride in 7 M urea in the mixing vessel and 1.8 l. of 0.005 N hydrochloric acid + 0.16 M sodium chloride in 7 M urea in the reservoir. Fractions of about 5.5 ml. were collected every 30 min.; - - - salt gradient; - - - - - pooling points. For the identification of peaks, see Table VII.

The total mixture of polynucleotides higher than the hexanucleotide was chromatographed on a DEAE-cellulose (chloride) column in the presence of 7 M urea. The conditions used and the elution pattern obtained is shown in Figure 3, and the distribution of

the nucleotidic material in different peaks is given in Table VII. Peak I contained mainly the octanucleotide which was freed from a minor impurity by treatment with the alkaline phosphatase followed by paper chromatography. The decanucleotide d-pT(pCpT)₄pC was the major component of peak III, and this too was further purified by treatment with the phosphomonoesterase followed by successive chromatography in two solvents.

Table VIII. Paper Chromatography of Deoxyribopolynucleotides Containing Alternating Thymidylate and Deoxycytidylate Units

Compound	Solvent D		Solvent E	
	R _f relative to pT	R _f relative to d-T-(pCpT) ₄ -pC	R _f relative to pT	R _f relative to d-T-(pCpT) ₄ -pC
Polynucleotides bearing 5'-phosphate end groups				
d-pTpC	0.79		0.94	
d-pTpCpTpC	0.50		0.61	
d-pT(pCpT) ₂ pC	0.28		0.39	
d-pT(pCpT) ₃ pC	0.12		0.30	
d-pT(pCpT) ₄ pC	0.07		0.23	0.45
d-pT(pCpT) ₅ pC				0.26
d-pT(pCpT) ₆ pC				0.18
d-pT(pCpT) ₇ pC				0.08
Polynucleotides lacking 5'-phosphate end groups				
d-TpC	1.43		1.35	
Cyclo-d-pTpC	1.21		0.96	
d-TpCpTpC	0.85		1.02	
Cyclo-d-pTpCpTpC	0.63		0.65	
d-T(pCpT) ₂ pC	0.42		0.76	
d-T(pCpT) ₃ pC	0.22		0.50	
d-T(pCpT) ₄ pC	0.16	1.00	0.33	1.00
d-T(pCpT) ₅ pC		0.53		0.68
d-T(pCpT) ₆ pC		0.24		0.39
d-T(pCpT) ₇ pC		0.15		0.18

Tables VIII and IX record the analytical data obtained on the homologous deoxyribopolynucleotides of this series. Thus in Table VIII are given the R_f values (in two solvents) of the polynucleotides up to the hexadecanucleotide d-T(pCpT)₇pC. While the complete purity of the deoxypolynucleotides higher than the decanucleotide is especially difficult to ascertain because of the large amounts that must be

Table IX. Phosphodiesterase Degradation of Deoxyribopolynucleotides Containing Alternating Thymidylate and Deoxycytidylate Units^a

Compound	d-C		Tp		d-Cp		Ratio	
	O.D./ml.	m μ -moles ^b	O.D./ml.	m μ -moles ^c	O.D./ml.	m μ -moles ^b	Found	Theor.
TpCpTpC ^d	0.384	29.5	0.580	60.4	0.395	30.4	1:2.05:1.03	1:2:1
T(pCpT) ₂ pC ^d	0.146	12.2	0.337	35.5	0.336	25.8	1:2.92:2.11	1:3:2
T(pCpT) ₃ pC ^e	0.319	24.6	1.006	104	0.988	76.0	1:4.22:3.09	1:4:3
T(pCpT) ₄ pC ^e		+		+		+		

^a The incubation was at 37° for 6 hr. under the standard conditions. The total incubation mixtures were chromatographed in solvent B. The spots corresponding to d-C, Tp, and d-Cp were eluted in 0.02 N hydrochloric acid (3 ml.) along with appropriate blanks. ^b Using a figure of 13,000 for ϵ_{\max} at 280 m μ for deoxycytidine and deoxycytidylic acid in 0.02 N hydrochloric acid. ^c Using a figure of 9600 for ϵ_{\max} at 267 m μ for thymidine and thymidylic acid in 0.02 N HCl. ^d These products were completely degraded by venom diesterase to the expected products. ^e These products were almost completely degraded by venom diesterase to the expected products; in the case of the decanucleotide the ratio of T:pT:d-pC was 1:4.08:5.47.

used for analysis with nucleolytic enzymes, it seems probable that they were essentially pure. The lower members which were available in larger quantities were characterized as pure by appropriate enzymic degradation (Table IX). An important feature of these results is that the degradation with the splenic phosphodiesterase went to completion in every case. (See below for side products which did, in fact, contain an internucleotidic linkage resistant to the splenic diesterase.)

Table X. Chromatography of Deoxypolynucleotides Obtained by Polymerization of the Protected Dinucleotide d-pA^{Bz}pG^{Ac} and Subsequent Removal of Protecting Groups^a

Peak no.	Tube	O.D. ₂₅₅ units	Total eluted, %	Compounds	Purity, %
I	318-340	190	8.7	Cyclo-d-pApGpApG	>90
II	340-380	330	15.2	d-pApGpApG	>90
III	496-540	290	13.4	d-pA(pGpA) ₂ pG	63
IV	600-620	160	7.3	d-pA(pGpA) ₃ pG	53
V	664-680	86	3.9	d-pA(pGpA) ₄ pG	32
VI	710-720	55	2.5	d-pA(pGpA) ₅ pG	

^a For details of column chromatography see text.

Deoxyribopolynucleotides Containing Alternating Deoxyadenylate and Deoxyguanylate Units. The protected dinucleotide¹⁶ d-pA^{Bz}pG^{Ac} (V) was polymerized by reaction with DCC essentially by the standard method and, after an acetic anhydride-pyridine treatment, an attempt was made to separate the polymeric products containing all the protecting groups on a DEAE-cellulose (carbonate) column. The separation was, however, poor and all the nucleotidic material larger than the dinucleotide was brought off with 1 M triethylammonium bicarbonate. The recovered products were treated with benzoic anhydride-pyridine to further ensure complete breakdown of pyrophosphate bonds and then treated with ammonia to remove the protecting groups. Separation was now effected by chromatography on a DEAE-cellulose (chloride) column in the presence of 7 M urea. The elution pattern obtained is shown in Figure 4 and the distribution of the nucleotidic material in different peaks

(16) Addition of the 3'-O-acetyl derivative of the protected dinucleotide to minimize cyclization of the dinucleotide was believed unnecessary, for in previous work on purine oligonucleotides the formation of cyclic dinucleotide was not significant [R. K. Ralph and H. G. Khorana, *J. Am. Chem. Soc.*, **83**, 2926 (1961)]. In the present experiment, however, 40% of the total product was the cyclic dinucleotide.

is given in Table X. The extent of purity of the various desired products in the peaks is also given in this table. For further purification, the nucleotidic material in each peak was chromatographed successively in solvents E and D.

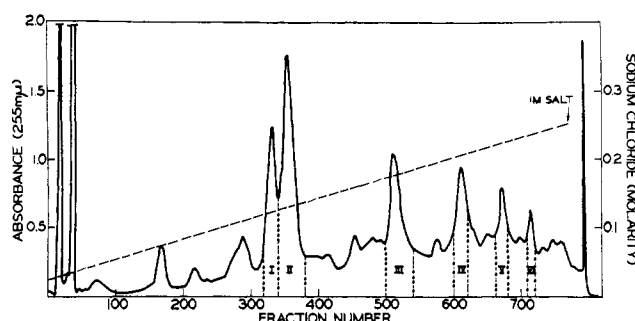

Figure 4. Chromatography of deoxyribopolynucleotides containing alternating deoxyadenylate and deoxyguanylate units on a DEAE-cellulose (chloride) column (40 cm. \times 2.0 cm.). Elution was carried out using a linear gradient of sodium chloride in 7 M urea (4 l. 0.025 M salt in the mixing vessel and 4 l. 0.25 M salt in the reservoir). Fractions of 10 ml. were collected every 10 min.; - - - salt gradient; pooling points. For the identification of peaks, see Table X.

The deoxypolynucleotide samples thus prepared were pure. Table XI gives the chromatographic properties of the members up to the decanucleotide. Further characterization was carried out by degradation with venom phosphodiesterase (Table XII) and with splenic phosphodiesterase after removal of 5'-phosphomonoester groups (Table XIII).

Deoxyribopolynucleotides Containing Alternating Deoxycytidylate and Deoxyadenylate Units. The polymerization of a mixture of d-pC^{An}pA^{Bz} (VI) and d-pC^{An}-pA^{Bz}-OAc was carried out by the standard method except that the period of reaction was reduced to only about 30 hr. While the extent of polymerization was distinctly less than in the reactions described above, the side products, as was hoped, were present in much smaller amounts. After the standard work-up, the products were separated by preparative paper chromatography. The individual bands observed and their relative concentrations are given in Table XIV. The tetra- and higher polynucleotides were further purified by treatment with the alkaline phosphatase and subsequent chromatography in solvent D.

Table XI. Paper Chromatography of Deoxypolynucleotides Containing Alternating Deoxyadenylate and Deoxyguanylate Units

Compound	— Solvent D —		— Solvent E —	
	R_f	R_f relative to d-pAp-GpApG	R_f	R_f relative to d-pAp-GpApG
Compounds bearing 5'-phosphate end groups				
d-pG	0.32		0.42	
d-pA	0.42		0.67	
d-pApG	0.27		0.53	
d-pApGpApG	0.12	1.0	0.30	1.0
d-pApGpApGpApG		0.32	0.16	
d-pA(pGpA) ₃ pG		0.16		0.29
d-pA(pGpA) ₄ pG		0.07		0.14
Compounds lacking 5'-phosphate end groups				
Cyclo-d-pApG	0.38		0.60	
Cyclo-d-pApGpApG	0.14		0.40	
d-ApG	0.53			
d-ApGpApG	0.22	1.80	0.51	
d-Ap(GpAp) ₂ G		0.80	0.31	
d-Ap(GpAp) ₃ G		0.35		0.72
d-Ap(GpAp) ₄ G		0.13		0.32

Table XII. Enzymic Characterization of Polynucleotides Containing Alternating Deoxyadenylate and Deoxyguanylate Units Using Venom Phosphodiesterase^a

Compound	Product of enzymic degradation				Ratio ^b of d-pG/d-pA
	d-pG		d-pA		
	O.D. ₂₅₂ units	μmoles	O.D. ₂₅₉ units	μmoles	
d-pApGpApG	5.80	0.423	6.00	0.390	1.08
d-pA(pGpA) ₂ pG	2.95	0.215	2.85	0.185	0.87
d-pA(pGpA) ₃ pG	4.20	0.306	4.45	0.289	1.06
d-pA(pGpA) ₄ pG	2.05	0.149	2.30	0.150	0.99

^a After incubation the products d-pA and d-pG were separated using solvent E. The relative concentrations were determined spectrophotometrically after elution of the nucleotides with water and adjusting to pH 7.5 with 0.05 M phosphate buffer. ^b Theoretical ratio is 1.0.

Table XIII. Enzymic Characterization of Polynucleotides Containing Alternating Deoxyadenylate and Deoxyguanylate Units Using Spleen Phosphodiesterase

Compound	Product of enzymic degradation				Found	Theor.
	d-G	d-Gp	d-Ap			
	O.D. ₂₅₂ units	O.D. ₂₅₂ units	O.D. ₂₅₉ units			
ApGpApG	2.85	3.00	6.30	1:1.04:2.00	1:1:2	
Ap(GpAp) ₂ pG	0.80	2.40	3.75	1:3.0:4.15	1:3:4	

Table XIV. Yields of Deoxypolynucleotides Containing Alternating Deoxycytidylate and Deoxyadenylate Units

Product	O.D. ^a at 260 mμ	Total eluted ^a %
Cyclo-d-pCpA	720	20.9
d-pCpA	1720	50.0
d-pCpApCpA	640	18.6
d-pC(pApC) ₂ pA	260	7.6
d-pC(pApC) ₃ pA	88	2.6
d-pC(pApC) ₄ pA and higher	10	0.3

^a The values given in this column are for major bands obtained on separation by paper chromatography in solvent D and do not represent the yields of the finally purified polynucleotides, as described in text.

The R_f values of the different members are given in Table XV. Characterization of the hexanucleotide d-CpApCpApCpA was also carried out by degradation with venom phosphodiesterase. The degradation proceeded to completion and the expected products were produced in the correct proportions.

Table XV. Paper Chromatography of Oligonucleotides Containing Alternating Deoxycytidine and Deoxyadenosine Units

Compound	— Solvent D —		— Solvent E —	
	R_f (relative to d-pA)	R_f [relative to d-pC-(pApC) ₂ -pA]	R_f (relative to d-pA)	R_f [relative to d-pC-(pApC) ₂ -pA]
Oligonucleotides bearing 5'-phosphate groups				
d-pCpA	0.80		0.84	
d-pCpApCpA	0.44		0.79	
d-pC(pApC) ₂ pA	0.20	1	0.76	1
d-pC(pApC) ₃ pA		0.41		0.89
d-pC(pApC) ₄ pA		0.14		
Oligonucleotides lacking 5'-phosphate groups				
Cyclo-d-pCpA	1.10		0.96	
d-CpApCpA	0.92			1.44
d-C(pApC) ₂ pA		2.29		1.31
d-C(pApC) ₃ pA		0.93		1.18
d-C(pApC) ₄ pA		0.44		1.01
d-C(pApC) ₅ pA		0.15		

Side Products. In the series of syntheses in which a time period of several days was used for the polymerization reactions, there was evidence for the presence of considerable amounts of side products in the polymeric mixtures. The nature of several of the side products was investigated in detail only in the mixture obtained on polymerization of the protected dinucleotide d-pTpC^{An}. However, it is believed that the side products encountered in the other polymerizations have similar structures.

Two main types of side products were identified, those bearing a 3'-phosphomonoester group at one end of the chain and a 5'-phosphomonoester group at the opposite end (e.g., VII),¹⁷ and second, those bearing 5'-phosphomonoester end groups at both ends together with an unnatural C₃'-C₃' internucleotidic linkage within the chain (e.g., VIIIa and VIIIb).¹⁷

Thus, thymidine diphosphate (pTp) contaminated the tetranucleotide d-pTpCpTpC on paper chromatograms and the pentanucleotide VII and the isomeric pentanucleotide VIII were the main components of peak II of Figure 3. (See Table XVI.) Similarly, the heptanucleotide d-pTpCpTpCpTpCpTp (IX) and its isomer with one C₃'→C₃' linkage (analogous to VIII) were present in peak IV of Figure 3, and it is probable that peaks VI and VIII from the same column contained higher homologs of the same series of side products.

(17) For convenience, diagrammatic representations are used in place of the full structural formulas. The system for these simplified representations is as has been described elsewhere (H. G. Khorana, "Some Recent Developments in the Chemistry of Phosphate Esters of Biological Interest," John Wiley and Sons, Inc., New York, N. Y., 1961). Note in particular the structure VIII in which C₃'→C₃' internucleotidic linkage is shown by drawing a line through lines connecting the letter P with the right-hand side (3'-hydroxyl of D-ribose) of the two vertical lines corresponding to the two deoxynucleosides.

Chart I. Characterization of Side Products by Enzymic Degradation

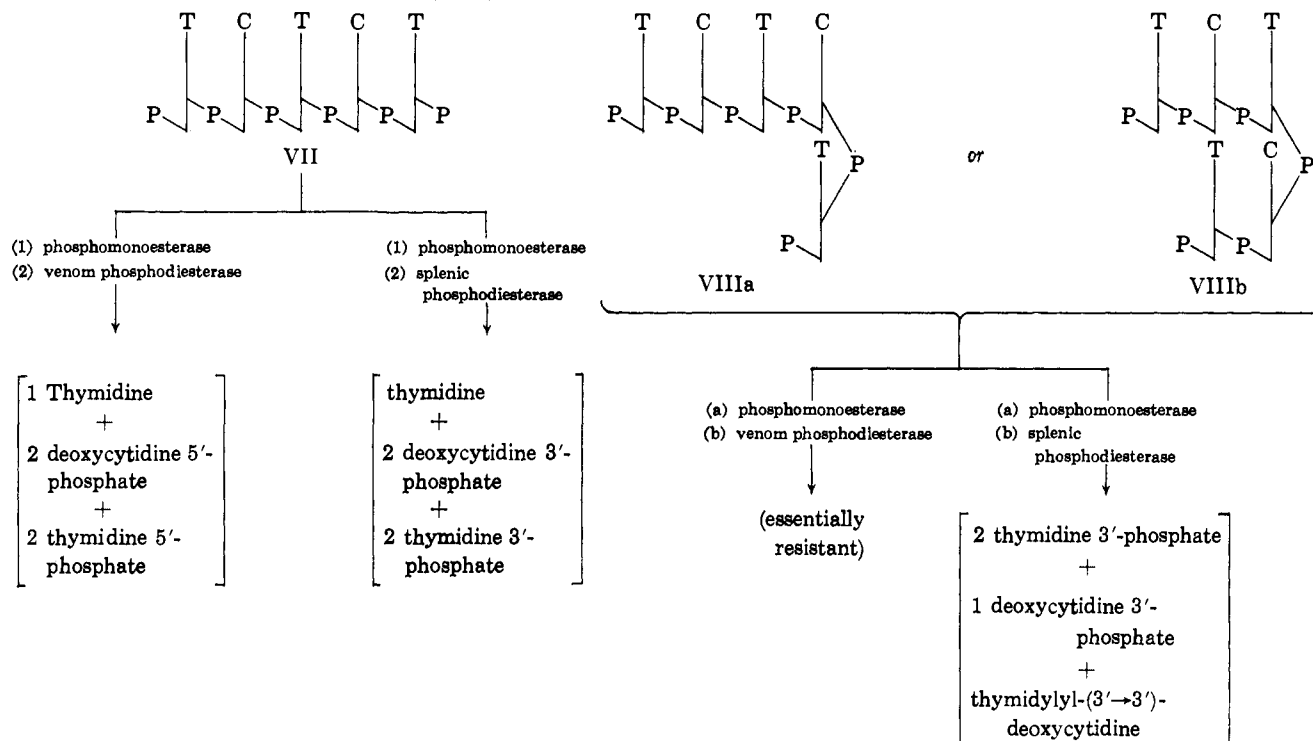

A common property of all the above side products, which suggested the presence of two phosphomonoester groups per molecule, was the striking increase in mobility on paper chromatography after treatment with the phosphomonoesterase (see, *e.g.*, Table XVI for

Table XVI. Paper Chromatography of Side Products in the Synthesis of Deoxypolynucleotides Containing Thymidylate and Deoxycytidylate Units in Alternating Sequence^a

Origin (peak no. of Figure 3)	Identification	—Solvent E R_f^b — Before ^c dephos- phoryl- ation	After ^c dephos- phoryl- ation	Peak, %
Peak II	d-pTpCpTpCpTp (VII)	0.34	0.84	55
Peak II	Isomer of VII with one 3'→3' linkage (VIII)	0.40	1.01	45
Peak IV	d-pTpCpTpCpTpCpTp (IX)	0.20	0.57	55
Peak IV	Isomer of IX with one 3'→3' linkage	0.20	0.68	45
Peak VI		0.16	0.42	
Peak VIII		0.11	0.22	

^a The products listed were obtained by further purification of some of the peaks of Figure 3. ^b R_f relative to that of pT. ^c This refers to the treatment with bacterial alkaline phosphatase for the removal of the phosphomonoester groups.

R_f values before and after phosphomonoesterase treatment), and this property was, in fact, frequently used for purification of the desired compounds from this series of side products. For example, the separation of d-pTpCpTpC and pTp was readily accomplished by paper chromatography after enzymic removal of the phosphomonoester groups.

Further work on structural assignment of the side products was carried out, as shown in Chart I, for components of peak II of Figure 3 (Table XVI). Thus, VII after removal of the phosphomonoester

groups was subjected to the action of the venom phosphodiesterase and of splenic phosphodiesterase. The products with the former enzyme were thymidine, deoxycytidine 5'-phosphate, and thymidine 5'-phosphate in the ratio 1:2:2. With splenic phosphodiesterase the two nucleoside 3'-phosphates, Tp and d-Cp, were produced and the terminal group was released as the nucleoside was again thymidine.

Compound VIII was also first treated with the phosphomonoesterase. The resulting product when treated with venom phosphodiesterase proved to be essentially resistant. The latter enzyme normally requires the presence of a 3'-hydroxyl group for degradation of an oligonucleotide chain,¹⁸ and the above finding therefore indicated the absence of a 3'-hydroxyl group in the product derived from VIII by the action of the phosphomonoesterase. The action of the splenic phosphodiesterase on the latter product proved particularly informative. The products formed were thymidine 3'-phosphate, deoxycytidine 3'-phosphate, and another product which in chromatographic properties resembled but was not identical with the dinucleoside phosphate, deoxycytidylyl-(3'→5')-thymidine. This new product was concluded to be deoxycytidylyl-(3'→3')-thymidine by direct comparison with a synthetic sample prepared by the condensation of N-benzoyl-5'-O-monomethoxytrityldeoxycytidine¹⁹ with 5'-O-trimethylacetylthymidine 3'-phosphate²⁰ followed by removal of the protecting groups (see Experimental). The unexpected resistance²¹ toward the splenic phosphodiester-

(18) W. E. Razzell and H. G. Khorana, *J. Biol. Chem.*, **234**, 2105 (1959).

(19) H. Schaller, G. Weimann, B. Lerch, and H. G. Khorana, *J. Am. Chem. Soc.*, **85**, 3821 (1963).

(20) G. Weimann and H. G. Khorana, *ibid.*, **84**, 4329 (1962).

(21) In a parallel experiment, thymidylyl-(3'→3')-deoxycytidine was totally unchanged under the conditions which caused complete degradation of thymidylyl-(3'→5')-deoxycytidine. The resistance of the compound to the diesterase is particularly interesting in view of the facile attack on compounds such as thymidine-3' *p*-nitrophenyl phos-

ase was also observed for the synthetic sample of C_3-C_3' linked dinucleoside phosphate. As expected, this product was also resistant to the action of the venom phosphodiesterase.

The total of evidence presented permits two possible structures,²² VIIa and VIIb, for the side product. It should be noted that the positions of elution of the side products listed in Table XVI from the DEAE-cellulose-urea column (Figure 3), which were run at acidic pH, are consistent with the above structures. Thus VII, a pentanucleotide with two deoxycytidine units, three thymidine units, and two phosphomonoester groups, would be expected to possess net negative charge at acidic pH no less than the octanucleotide which preceded VII in peak I (Figure 3).

Formation of side products bearing 3'-phosphomonoester end groups has been observed previously in work on the stepwise synthesis of deoxyribopolynucleotides.²³ Their formation during polymerization may be explained analogously by the reaction illustrated in the partial formulas X-XIII.

Pyridinium compounds, represented by the partial structure XI, would be expected to be formed concomitantly, and these were indeed demonstrated to be

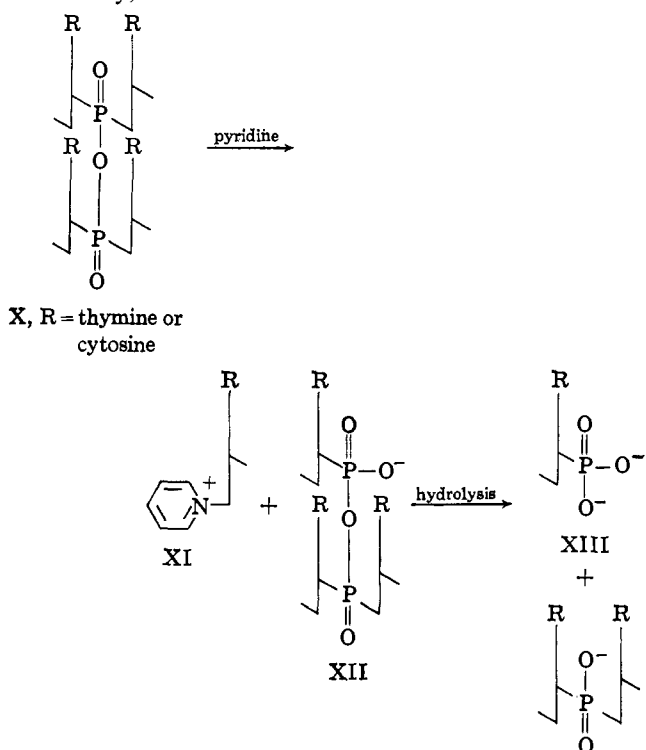

present in the previous work.²³ In the present work the "accounting" of this series of side products was not nearly as complete as that of the series bearing phosphomonoester groups, but evidence for their presence was obtained in the polymeric mixtures containing alternating deoxyadenylate and deoxyguanylate units. It should be emphasized that compounds of the type XI would not have phosphomonoester end groups and would, in general, have low net negative charge, and it is highly probable that they were eluted very

[W. E. Razzell and H. G. Khorana, *J. Biol. Chem.*, **236**, 1144 (1961)].

(22) The higher homolog, a heptanucleotide with one C_3-C_3' internucleotidic linkage (Table XVI) may possess three possible isomeric structures.

(23) T. M. Jacob and H. G. Khorana, *J. Am. Chem. Soc.*, **87**, 368 (1965).

early from the anion-exchanger columns and were in the fractions not subjected to close scrutiny.

The formation of side products with a C_3-C_3' internucleotidic linkage has been detected for the first time.²⁴ One mechanism for their formation is the prior formation of a 3'-phosphomonoester as described above and the subsequent activation of this group which results in the phosphorylation of the 3'-hydroxyl group of an oligonucleotide. However, a second scheme which would be expected to make greater contribution involves the initial formation of a neutral ester by phosphorylation of the terminal 3'-hydroxyl group with an activated internucleotidic linkage. This esterification could occur intramolecularly²⁵ (e.g., XIV) or intermolecularly as in structure XV.²⁶ The triester may then be broken down by pyridine during the reaction, or during the alkaline treatment in the work-up. In each case, the attack would be expected to occur at the C_5' carbon rather than at the disubstituted C_3' carbon atom, thereby generating a C_3-C_3' internucleotidic linkage. The intramolecular reaction would result in the formation of by-products having an even number of nucleotides, one phosphomonoester end group, and either a 5'-hydroxyl (XVI) or pyridinium residue (XVII) at the opposite end of the chain. Products of this type have not been identified as yet. The intermolecular reaction (XV) would lead to the formation of compounds with two 5'-phosphomonoester end groups in addition to the 3'-3' linkage (e.g., VII) and would also yield a second fragment bearing a 5'-hydroxyl or pyridinium function.

Finally, it should be mentioned that, with the clear evidence of the intermediate formation of some triester of phosphoric acid (as depicted in XIV and XV), the possibility of cyclonucleoside formation²⁷ and consequent inversion of the 3'-hydroxyl group at that point was considered. Such products, e.g., XVIII, with the nucleoside at right-hand terminus having an inverted 3'-hydroxyl group, might have contaminated the desired deoxypolynucleotide. An adequate amount (8 O.D. units) of the tetranucleotide d-TpCpTpC was therefore degraded with the splenic phosphodiesterase, and the nucleoside released was compared with deoxycytidine and a sample of 1-(2'-deoxy-D-threo-pentofuranosyl)cytosine prepared by a method analogous to that published in the literature for related compounds.²⁸

(24) It should be emphasized that in essentially all the extensive synthetic work reported in previous papers the synthetic products were checked carefully for complete degradation by phosphodiesterases at rather high concentration. It is highly improbable that an impurity with C_3-C_3' linkage was missed. The formation of this kind of by-product in the present work is ascribed to the very sluggish nature of the polymerization reaction as applied to dinucleotides and, consequently, an exceptional opportunity for side reactions to occur.

(25) Cf. the facile intramolecular cyclic di- and trinucleotide formation: G. M. Tener, H. G. Khorana, R. Markham, and E. H. Pol, *J. Am. Chem. Soc.*, **80**, 6224 (1958); H. G. Khorana and J. P. Vizsolyi, *ibid.*, **83**, 675 (1961).

(26) One case where an intramolecular neutral ester formation occurred has been described previously: G. Weimann and H. G. Khorana, *ibid.*, **84**, 419 (1962). However, there one secondary hydroxyl and two primary hydroxyl groups were involved.

(27) The tertiary phosphate ester could be a good leaving group although not as powerful as the tosylate ion. The tosyl esters have been shown to undergo anhydronucleoside formation by the rear side attack of the 2-keto group in pyrimidines. For a review see A. M. Michelson, "The Chemistry of Nucleosides and Nucleotides," Academic Press, Inc., New York, N. Y., 1963.

(28) J. J. Fox and N. C. Miller, *J. Org. Chem.*, **28**, 936 (1963); J. P. Horwitz, J. Chua, J. A. Urbanski, and M. Noel, *ibid.*, **28**, 942 (1963).

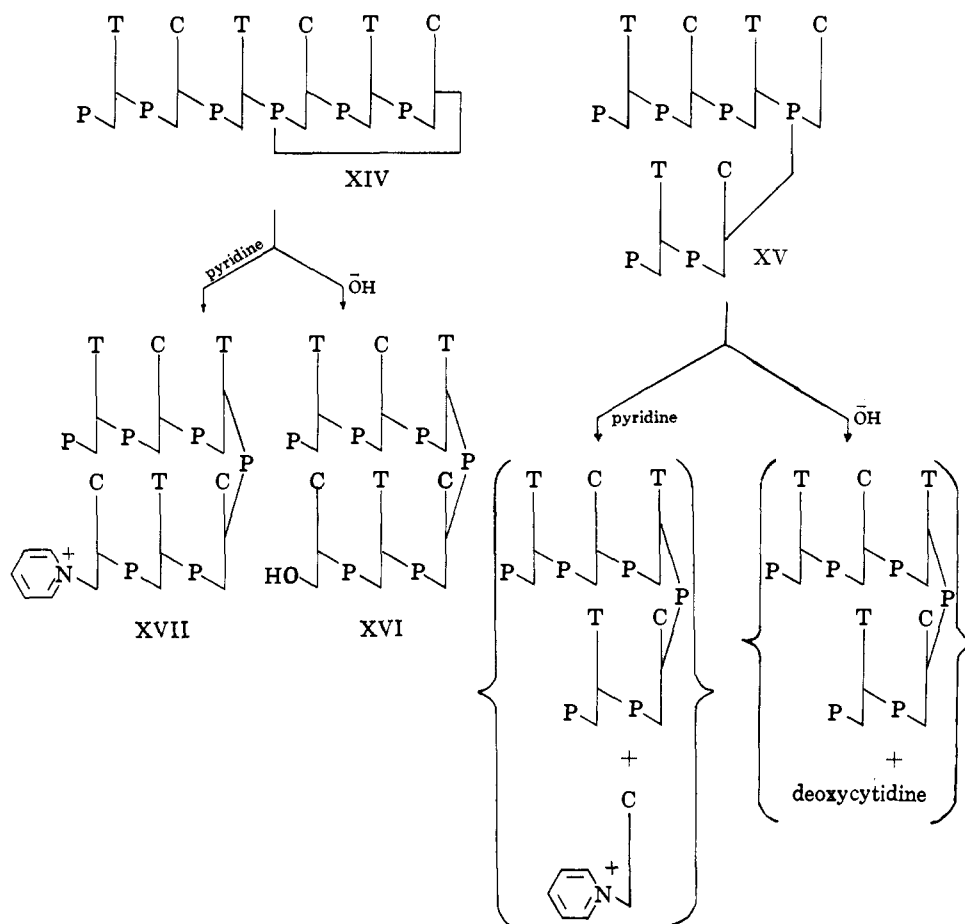

Only deoxycytidine was detected by paper electrophoresis in the borate system, which separated the two nucleosides well.²⁹

Concluding Remarks. While the polymerization procedure as available at present is not very efficient and the desired products have to be separated carefully from the side products, the method does provide a rather rapid means of obtaining modest quantities of short-chain deoxyribopolynucleotides containing repeating dinucleotide sequences. It is advisable to keep the reaction periods for polymerization to a minimum as was done in the preparation of members containing deoxycytidylate-deoxyadenylate units.

Extremely small amounts of materials were adequate for the study of the synthetic deoxypolynucleotides herein described as templates for the deoxyribonucleic acid polymerase and, as reported elsewhere,^{30,31} DNA-like polymers of high molecular weight were successfully prepared with the strictly repeating nucleotide sequences provided in the short-chain synthetic deoxyribopolynucleotides.

(29) M. P. Gordon, O. M. Intrieri, and G. B. Brown, *J. Am. Chem. Soc.*, **80**, 5161 (1958).

(30) C. Byrd, E. Ohtsuka, M. W. Moon, and H. G. Khorana, *Proc. Natl. Acad. Sci. U. S. A.*, **53**, 79 (1965).

(31) R. D. Wells, E. Ohtsuka, and H. G. Khorana, unpublished work.

Experimental

General Methods. Paper chromatography was performed by the descending technique using mostly Whatman No. 40 or Whatman No. 1 paper. The solvent systems used were: solvent A, isopropyl alcohol-concentrated ammonia-water (7:1:2, v./v.); solvent B, ethyl alcohol-0.5 M ammonium acetate, pH 3.8 (7:3, v./v.); solvent C, ethyl alcohol-1 M ammonium acetate, pH 7.5 (7:3, v./v.); solvent D, *n*-propyl alcohol-concentrated ammonia-water (55:10:35); solvent E, isobutyric acid-concentrated ammonia-water (66:1:33); solvent F, isobutyric acid-concentrated ammonia-water (57:4:39); solvent G, saturated ammonium sulfate-0.1 M sodium acetate (pH 6.5)-isopropyl alcohol (79:19:2).

Paper electrophoresis was carried out in an apparatus similar to that of Markham and Smith³² or in a commercially available apparatus designed on the same principle and capable of giving a potential of 5000 v. The buffers used were potassium phosphate (0.03 M, pH 7.1) and ammonium formate-formic acid (0.05 M, pH 2.7).

Enzymic degradation of the synthetic products using bacterial alkaline phosphomonoesterase, spleen phosphodiesterase, and purified venom phosphodiesterase were performed as described previously.³³

The abbreviation O.D.₃₀₂ refers to the extinction of a nucleotidic solution at neutral pH in a 1-ml. solution using a 1-cm. light path quartz cell.

(32) R. Markham and J. D. Smith, *Biochem. J.*, **52**, 552 (1952).

(33) H. G. Khorana, A. F. Turner, and J. P. Vizolyi, *J. Am. Chem. Soc.*, **83**, 686 (1961).

β -Cyoanoethyl Thymidine 5'-Phosphate. A mixture of pyridinium thymidine 5'-phosphate (2.55 mmoles), hydroacrylonitrile (5 ml., 72 mmoles), pyridine (5 ml.), and DCC (5.15 g., 25 mmoles) was allowed to stand at room temperature for 21 hr. Paper electrophoresis at this stage showed complete disappearance of thymidylic acid, the products being β -cyanoethyl thymidine 5'-phosphate and the neutral di- β -cyanoethyl thymidine 5'-phosphate. Water (40 ml.) was added and the mixture was extracted with pentane. After 3 days at room temperature the aqueous pyridine solution was adjusted to pH 9 with 2 *N* ammonium hydroxide and the solution was allowed to stand for a further 18 hr. at room temperature. This treatment caused complete conversion of the neutral ester to β -cyanoethyl thymidine 5'-phosphate. Ammonium ions were removed by passing the solution through a column of pyridinium Dowex 50 ion-exchange resin, and the column effluent and washings were evaporated with frequent addition of pyridine. The anhydrous residue was dissolved in dry pyridine (20 ml.) and added dropwise to ether (500 ml.), at which point a gummy precipitate separated. The ethereal solution was centrifuged and the solid was dissolved in pyridine (20 ml.) and reprecipitated in ether (500 ml.). The precipitated β -cyanoethyl thymidine 5'-phosphate (1.9 mmoles, 75%) was homogeneous by paper electrophoresis and paper chromatography (Table I).

A further quantity of the product could be recovered from the ethereal solution by evaporation followed by chromatography of the residue on a DEAE-cellulose ion-exchange column.

5'-O-Phosphorylthymidylyl-(3'→5')-N⁶-anisoyldeoxycytidine (d-pTpC⁴ⁿ). An aqueous pyridine solution of pyridinium 3'-O-acetyl-N⁶-anisoyldeoxycytidine 5'-phosphate (1.8 mmoles) and pyridinium β -cyanoethyl thymidine 5'-phosphate (1.8 mmoles) was rendered anhydrous by repeated evaporation of pyridine. Dimethylformamide (3 ml.) and Dowex 50 pyridinium ion-exchange resin (1 g.) was added to the residue which no longer gave a clear solution in anhydrous pyridine, and the mixture was again evaporated after addition of pyridine. Pyridine (20 ml.) was added to the residual gum and the solution was shaken to dissolve as much of the nucleotidic material as possible. DCC (0.5 g.) was added and the mixture was warmed to 40° for several minutes. A further quantity of DCC (1.5 g.) was then added and the solution was again warmed until all the nucleotidic starting materials were in solution. The solution was concentrated to 10 ml., more DCC (0.5 g.) was added, and the mixture was allowed to stand at room temperature for 3 days. Water (3 ml.) was then added and the solution was extracted with cyclohexane (two 20-ml. portions). The aqueous pyridine solution (30 ml.) was treated at 0° with 30 ml. of 2 *N* sodium hydroxide solution. After 20 min. an excess of Dowex 50 (pyridinium) resin was added and, after thorough shaking, the resin was removed by filtration and washed with water. The filtrate and washings were concentrated to about 20 ml. and this solution was applied on top of a DEAE-cellulose (carbonate) column (45 × 4 cm.). Elution was carried out at 3° using a linear gradient of triethylammonium bicarbonate (4 l. of 0.01 *M* triethylammonium bicarbonate in the mixing

vessel and 4 l. of 0.3 *M* triethylammonium bicarbonate in the reservoir), fractions of about 19 ml. being collected every 15 min. Fractions 234-278 contained the protected dinucleotide which was homogeneous on paper chromatography and paper electrophoresis. The combined eluate was passed through a column of Dowex 50 pyridinium resin and the total effluent and washings were concentrated by evaporation in the presence of pyridine. The yield was 19,550 O.D.₃₀₂ units (0.87 mmole, 48%). The ultraviolet absorption characteristics at pH 7.5 were λ_{\max} 302 and 207 m μ ; λ_{\min} 295 and 240 m μ , $\epsilon_{302}/\epsilon_{260}$, 0.73. The product was homogeneous by paper chromatography (Table I). Treatment with concentrated ammonia gave 5'-O-phosphorylthymidylyl-(3'→5')-deoxycytidine as the only nucleotidic material (*R_f* values shown in Table I).

Acetylation of 5'-O-Phosphorylthymidylyl-(3'→5')-N⁶-anisoyldeoxycytidine. The dinucleotide (5000 O.D.₃₀₂ units) was rendered anhydrous with pyridine and allowed to react with acetic anhydride (0.5 ml.) in pyridine (2 ml.) for 4 hr. Methanol (1 ml.) was added with cooling, and the mixture was kept for 1 hr. at room temperature. Water (2 ml.) was then added and the solution was kept for 15 hr. more. The solvent was removed by evaporation, and the resulting gum was dried by repeated evaporation of pyridine and finally dissolved in pyridine (5 ml.). This solution was added to dry ether (40 ml.) and the precipitate was collected by centrifugation, washed with ether, and dried.

β -Cyoanoethyl N-Benzoyldeoxyadenosine 5'-Phosphate. A mixture of pyridinium N-benzoyldeoxyadenosine 5'-phosphate (66,000 O.D.₂₈₂ units, 3.6 mmoles), hydroacrylonitrile (8.7 ml., 130 mmoles), pyridine (10 ml.), and DCC (2.45 g., 12 mmoles) was shaken at room temperature for 3 days. After subsequent addition of water (25 ml.) the reaction mixture was extracted with cyclohexane (two 50-ml. portions) to remove unreacted DCC. The aqueous phase was filtered to remove the crystalline dicyclohexylurea and applied to the top of a DEAE-cellulose (bicarbonate) column (100 × 5 cm.). The column was eluted with water and then with a linear salt gradient (4 l. of water in the mixing vessel and 4 l. of 0.1 *M* ammonium bicarbonate in the reservoir). After elution of a neutral nucleotidic product (*R_f* 0.88 in solvent C), the required β -cyanoethyl N-benzoyldeoxyadenosine 5'-phosphate was eluted at a salt concentration of 0.025 *M*. The product (40,800 O.D.₂₈₂ units, 62% yield) was homogeneous by paper chromatography in solvent C (Table I).

5'-O-Phosphoryl-N-benzoyldeoxyadenylyl-(3'→5')-N-acetyldeoxyguanosine (d-pA^{Bp}G^{Ac}). An anhydrous solution of pyridinium β -cyanoethyl N-benzoyldeoxyadenosine 5'-phosphate (10,000 O.D.₂₈₂ units, 0.625 mmole), pyridinium N,3'-O-diacetyldeoxyguanosine 5'-phosphate (1.0 mmole), pyridinium Dowex 50 ion-exchange resin (250 mg.), and DCC (0.75 g.) in pyridine (2 ml.) was shaken for 4 days at room temperature. Water (10 ml.) followed by cyclohexane (20 ml.) were then added and mixture was filtered to remove dicyclohexylurea. The aqueous phase was separated and again extracted with cyclohexane (20 ml.) to remove completely DCC. An equal volume of 2 *N* sodium hydroxide was added to the aqueous solution and after

10 min. at 0° an excess of pyridinium Dowex 50 ion-exchange resin was added to remove sodium ions. The resin was removed by filtration and washed with aqueous pyridine. The total filtrate was concentrated and applied to the top of a DEAE-cellulose (bicarbonate form) column (40 × 5 cm.). Elution was carried out at 4° with a linear salt gradient (4 l. of water in the mixing vessel and an equal volume of 0.4 M ammonium bicarbonate in the reservoir). Fractions of 20 ml. were collected at a flow rate of 2 ml./min. Pure protected dinucleotide (d-pA^{Bz}pG^{Ac}) was eluted from the column in fractions 235–275. The yield was 8800 O.D.₂₇₈ units (0.30 mmole, 47%). The spectral characteristics were λ_{\max} 278 and 262 m μ ; λ_{\min} 268 and 228 m μ ; $\epsilon_{262}/\epsilon_{278}$ 0.94; $\epsilon_{268}/\epsilon_{278}$ 0.91; $\epsilon_{228}/\epsilon_{278}$ 0.51; calculated ϵ_{\max} (278 m μ) 29,500. The product was homogeneous on paper chromatography in solvent C (R_f values shown in Table I) and after removal of the protective groups with ammonia gave the dinucleotide d-pApG, which was homogeneous on chromatography in solvents D and C (Table I).

5'-O-Phosphoryl-N⁶-anisoyldeoxycytidylyl-(3'→5')-N⁶-benzoyldeoxyadenosine. An anhydrous mixture of pyridinium 3'-O-acetyl-N⁶-benzoyldeoxyadenosine 5'-phosphate (0.7 mmole), pyridinium β -cyanoethyl N⁶-anisoyldeoxycytidine 5'-phosphate (0.7 mmole), and pyridinium Dowex 50 ion-exchange resin (0.5 g.) in pyridine (5 ml.) was treated with DCC (0.8 g.) for 3 days at room temperature. Water (5 ml.) was then added and the mixture was extracted with cyclohexane (three 10-ml. portions). After 16 hr. at room temperature, the aqueous pyridine solution was treated with 2 N sodium hydroxide (10 ml.) for 20 min. at 0°. (The amount of water and pyridine were adjusted at the start of hydrolysis to obtain a clear solution.) The solution was neutralized with an excess of pyridinium Dowex 50 resin and the resin was removed by filtration and washed with aqueous pyridine. The total filtrate was concentrated and applied on top of a DEAE-cellulose column (45 × 2.5 cm., acetate form). Elution was carried out with a linear salt gradient (0.02 M triethylammonium acetate (4 l.) in the mixing vessel and 0.3 M triethylammonium acetate (4 l.) in the reservoir, both solutions containing 25% ethanol). The protected dinucleotide was eluted between 0.19 and 0.24 M salt concentration and amounted to 6650 O.D.₃₀₂ units. The spectral properties were λ_{\max} 286 m μ ; λ_{\min} 241 m μ in 0.05 M Tris buffer at pH 8.0. The product was homogeneous on paper chromatography and on electrophoresis (Table I). Treatment with concentrated ammonia afforded the dinucleotide (d-pCpA) which had the following properties: λ_{\max} 262 m μ ; λ_{\min} 230 m μ in 0.05 M Tris buffer at pH 8.0; for R_f values see Table I.

Acetylation of the Dinucleotide d-pC^{An}pA^{Bz}. The dinucleotide (1600 O.D.₃₀₂ units) was kept in a mixture of acetic anhydride (0.25 ml.) and pyridine (1 ml.) for 4 hr. at room temperature. Methanol (0.5 ml.) was added with cooling and 15 min. later water (1 ml.) was added. After 4 hr. the solution was concentrated in the presence of pyridine and the anhydrous residue was dissolved in pyridine (2 ml.). The product was precipitated by the dropwise addition of this solution to an excess of ether (40 ml.). The precipitate was collected, washed

with ether, and dried. The product had R_f 0.49 in solvent C.

Polymerization of a Mixture of 5'-O-Phosphorylthymidylyl-(3'→5')-N-acetyldeoxyguanosine and 5'-O-Phosphorylthymidylyl-(3'→5')-N,3'-O-diacetyldeoxyguanosine. The dinucleotide d-pTpG^{Ac} (4500 O.D.₂₅₉ units, about 0.18 mmole) was acetylated to give d-pTpG^{Ac}-OAc. A mixture of the pyridinium salts of the acetylated product and the dinucleotide d-pTpG^{Ac} (13,500 O.D.₂₅₉ units) and pyridinium Dowex 50 ion-exchange resin (350 mg.) was rendered anhydrous by repeated evaporation of added pyridine. The residual gum was dissolved in anhydrous dimethylformamide (1 ml.) and a solution of DCC (0.6 g.) in pyridine (1 ml.) was added dropwise. About one-fourth of the reagent was added under agitation in 5 min. The transient formation of a gummy precipitate was observed after each addition, but thorough mixing gave a clear solution until more than one-half of the DCC had been added. The remainder of the reagent was added rapidly and caused considerable coagulation of the mixture. After vigorous agitation, most of the solvent was removed *in vacuo* and the gummy reaction mixture was kept in the dark at room temperature for 7 days. A mixture of water (1 ml.) and pyridine (1 ml.) was then added and, after mixing, the aqueous pyridine solution was extracted with cyclohexane three times. After 4 hr., the resin and dicyclohexylurea were removed by filtration and the filtrate was evaporated repeatedly to dryness with added pyridine. The gummy product was dissolved in tri-*n*-butylamine (0.4 ml.) and pyridine (5 ml.) and treated with acetic anhydride (3 ml.) overnight. Water (10 ml.) was added with cooling and after 4 hr. most of pyridinium acetate was removed by repeated evaporation of added aqueous pyridine. The residue was dissolved in 10% pyridine and passed through a column of pyridinium Dowex 50 ion-exchange resin, and the total effluent and washings were lyophilized. The dry powder thus obtained was washed with ether and dissolved in pyridine and tri-*n*-butylamine (0.5 ml.). Pyridine was evaporated and the residue was treated with benzoic anhydride (5 g.) in dry pyridine (10 ml.) for 24 hr. Water (10 ml.) was then added and the aqueous pyridine solution was kept for 2 hr. at room temperature and then extracted with ether. The aqueous pyridine solution was now treated with an excess of concentrated ammonium hydroxide solution for 2 days, after which time ammonia was evaporated.

Separation and Characterization of Deoxyribopolynucleotides Containing Alternating Deoxythymidylate and Deoxyguanylate Units. (A) Use of DEAE-Cellulose (Acetate) Column. An aliquot (10% of the total polymeric mixture obtained in the preceding experiment) was applied to the top of a DEAE-cellulose (acetate) column (50 × 1.1 cm. in diameter) pre-equilibrated with 50% ethyl alcohol. Elution was carried out using a linear gradient of triethylammonium acetate (pH 6.5). The conditions used and the elution pattern obtained are shown in Figure 1 and the distribution of the ultraviolet absorbing material is shown in Table II. The identification of the products in different peaks is also given in this table. Peak VII contained pure d-pTpGpTpG, the product being homogeneous on paper chromatography in solvents

D and F (for R_f values see Table III). After bacterial alkaline phosphomonoesterase treatment the product showed a single band (14 O.D. level) in solvents D and E. The dephosphorylated product, d-TpGpTpG, was characterized by degradation with venom and spleen diesterase. The results are given in Table IV.

Peak VIII of Figure 1 contained d-pTpGpTpGpTpG as the major product (88%), but in addition two other minor products which were separated after phosphomonoesterase treatment by chromatography in solvent D. The hexanucleotide thus purified was also homogeneous in solvent F. The results of enzymatic characterization are given in Table IV.

(B) *Use of Preparative Paper Chromatography and DEAE-Cellulose-Urea Chromatography.* A part (40%) of the total polymeric mixture of preceding experiment was applied to 12 strips (each 9 in. wide) of Whatman No. 40 paper and the mixture was chromatographed in solvent D for 69 hr. Clear resolution into bands was observed up to the hexanucleotide d-pTpGpTpGpTpG, which also served as the marker. Octa- and higher polynucleotides, which traveled slower, were all eluted together with 1 *M* ammonium hydroxide. Ammonia was partly removed and the total mixture (481 O.D.₂₅₆ units at pH 7.5) was applied on top of a DEAE-cellulose (chloride form) column (60 × 1.5 cm.). Elution was carried out using a linear salt gradient. The condition used and the elution pattern are shown in Figure 2, and the distribution of the nucleotidic material in different peaks is given in Table V.

Further Purification of Higher Deoxypolynucleotides Containing Alternating Thymidylate and Deoxyguanylate Units. Peak IV of Figure 2 contained pure octanucleotide d-pT(pGpT)₃pG.

Peak VI of Figure 2 contained mainly the decanucleotide d-pT(pGpT)₄pG. It was purified further by treatment with the bacterial alkaline phosphatase followed by chromatography in solvent F. An impurity (17%), now traveling between d-TpGpTpGpTpG and d-T(pGpT)₃pG, was thus removed.

Peak VIII of Figure 2 contained the dodecanucleotide. This was further purified as described above for the decanucleotide.

Polymerization of a Mixture of 5'-O-Phosphorylthymidylyl-(3'→5')-N⁶-anisoyldeoxycytidine and 5'-O-Phosphorylthymidylyl-(3'→5')-N⁶-anisoyl-3'-O-acetyldeoxycytidine. An aqueous pyridine solution of the pyridinium salts of the N-protected dinucleotide (d-pTpC^{An}) (15,650 O.D.₃₀₂ units, 0.7 mmole) and the corresponding acetylated derivative (d-pTpC^{An}-OAc) (about 0.22 mmole) was rendered anhydrous by repeated evaporation of added pyridine. The gum was dissolved in dimethylformamide (1 ml.) and pyridine (1 ml.), pyridinium Dowex 50 resin (0.5 g.) was added, and all the components of the reaction mixture were rendered anhydrous by evaporation of three portions of dry pyridine. To the residual sirup were added dimethylformamide (1.5 ml.) and pyridine (0.5 ml.), and the solution was concentrated to about 1 ml. A solution of DCC (0.85 g.) in pyridine (1.0 ml.) was added dropwise to the mixture under agitation. The reaction mixture was homogeneous until two-thirds of the DCC solution had been added (time taken, 30 min.) A gel separated on further addition of the DCC

solution and the solution was shaken for 1 hr. before addition of the rest of the DCC. The addition of the last portion caused the formation of a gum. Most of the solvents were removed by evaporation *in vacuo* and the residual mixture was kept for 6 days. Pyridine (2 ml.) and water (2 ml.) were then added and, after extraction with cyclohexane, the aqueous pyridine solution was evaporated. The anhydrous residue (evaporation of added pyridine) was treated with acetic anhydride (3 ml.) in pyridine (5 ml.) for 14 hr. Water (1 ml.) was then added and the solution was kept for 4 hr., after which it was evaporated repeatedly with pyridine and lyophilized. One-half of the polymeric mixture was treated at room temperature with benzoic anhydride (5.4 g.) in pyridine (10 ml.), and after 24 hr. the solution was added dropwise to an excess (200 ml.) of dry ether. The precipitate which formed was washed with ether and dissolved in 50% aqueous pyridine (10 ml.), and this solution was treated with 2 *N* sodium hydroxide (10 ml.) for 5 min. at 0°. Sodium ions were then removed by the addition of an excess of pyridinium Dowex 50 ion-exchange resin, and the filtrate and washings from the resin were concentrated to a gum. This was taken up in pyridine (5 ml.) and the solution was treated with concentrated ammonia (10 ml.) for 2 days. After removal of a large part of ammonia the polymeric mixture was divided into portions for separation by different methods.

Separation of Deoxyribopolynucleotides Containing Alternating Thymidylate and Deoxycytidylate Units.

(A) *Separation by Preparative Paper Chromatography.* A part (40%) of the polymeric mixture obtained in the preceding experiment was applied to 12 9-in. wide strips of Whatman paper 40 and the mixture was chromatographed in solvent D for 35 hr. Several clearly separated bands corresponding to lower homologs were observed. The relative amounts of the different products are shown in Table VI (column A).

The band corresponding to the tetranucleotide (d-pTpCpTpC) contained two impurities (pTp, 14% of total, and another unidentified product, 9%). For further purification the total was treated with bacterial alkaline phosphatase and the resulting products chromatographed in solvent E. The major band thus obtained corresponded to pure d-TpCpTpC. For recovery from paper, the chromatographic band was first dipped in 95% ethyl alcohol to remove isobutyric acid and its salt and was then air-dried.

The band corresponding to the hexanucleotide d-pTpCpTpCpTpC was eluted and, for further purification, a portion was treated with bacterial alkaline phosphatase. The resulting product, d-TpCpTpCpTpC, was chromatographed in solvent D. This step removed a trace (1.5%) impurity traveling faster and another impurity (10.5%) traveling slower. The major band of the desired product was eluted and rechromatographed in solvent E. A trace of another slow travelling compound was thus removed. The hexanucleotide now obtained was pure (R_f values given in Table VIII) and was further characterized by enzymic degradation (Table IX).

(B) *Separation of Higher Polynucleotides Using DEAE-Cellulose-Urea Chromatography.* The total mixture of polynucleotides higher than the hexanucleotide d-pTpCpTpCpTpC, obtained by preparative paper

chromatography under method A, above, was eluted (total product, 1150 O.D.₂₇₀ units). It was applied to a DEAE-cellulose (chloride) column (54 × 1.5 cm.) pre-equilibrated with 0.02 M sodium chloride + 7 M urea. The elution condition and the pattern are shown in Figure 3 and the distribution of nucleotidic material is given in Table VII.

Further Purification of Higher Deoxypolynucleotides Containing Alternating Thymidylate and Deoxycytidylate Units. (A) *The Octanucleotide d-pT(pCpT)₃pC.* Peak I of Table II was treated with bacterial alkaline phosphatase and the product was chromatographed in solvent E. The main band was eluted and applied to a DEAE-cellulose column (37 × 1 cm.) pre-equilibrated with 0.06 M sodium chloride in 7 M urea. Elution of the column afforded a single peak at the salt concentration 0.12 M sodium chloride in 0.005 N hydrochloric acid and 7 M urea. The isolated material was homogeneous in solvent D and was characterized by degradation with spleen and venom phosphodiesterases (Table IX).

(B) *The Decanucleotide d-pT(pCpT)₄pC.* Peak III of Table II was treated with bacterial alkaline phosphatase and the product was further purified by successive paper chromatography in solvents D and E. Its characterization is shown in Table IX.

Thymidyl-(3'→3')-deoxycytidine. N-Benzoyl-5'-O-monomethoxytrityldeoxycytidine (0.05 mmole) and pyridinium 5'-O-trimethylacetylthymidine 3'-phosphate²⁰ (0.05 mmole) were allowed to react with DCC (0.25 mmole) in pyridine (0.25 ml.). After 3 days, 50% aqueous pyridine (0.5 ml.) was added, DCC was extracted with cyclohexane, and the mixture was kept overnight. Pyridine (1 ml.) and concentrated ammonium hydroxide (1 ml.) were then added and the total mixture was set aside at room temperature. After 2 days, ammonia and pyridine were removed *in vacuo* and residual pyridine was removed by re-evaporation after addition of water. The residue was treated with 80% acetic acid (5 ml.) for 3 hr. at room temperature. Acetic acid was removed *in vacuo*, the removal being completed by repeated evaporation after addition of water. The residue was washed with ether and then dissolved in water (0.2 ml.). The aqueous solution was applied to two sheets of Whatman 3 MM paper in solvent A. A band corresponding to the dinucleoside phosphate (R_f relative to pT 3.4)³⁴ was eluted with water. The aqueous solution was passed through a small column of ammonium Dowex 50 resin, and the effluent and washings were concentrated to a small volume. On paper electrophoresis at pH 7.5 (0.1 M triethylammonium bicarbonate) the mobility of this product was identical with that of thymidyl-(3'→5')-deoxycytidine (0.54 relative to pT). The yield of the product was about 25%. The compound was completely resistant to the action of spleen phosphodiesterase and of crude *Crotalus adamanteus* snake venom under the conditions which caused complete degradation of thymidyl-(3'→5')-deoxycytidine by these preparations.

Polymerization of 5'-O-Phosphoryl-N-benzoyldeoxyadenyl-(3'→5')-N-acetyldeoxyguanosine. A pyridinium solution of the pyridinium salt of the protected dinucleo-

tide d-pA^{Bz}pG^{Ac} (8500 O.D.₂₇₈ units, about 0.30 mmole) was evaporated to a gum under reduced pressure. Anhydrous pyridinium Dowex 50 ion-exchange resin (400 mg.), pyridine (5 ml.), and dimethylformamide (1 ml.) were added and, after thorough mixing, the mixture was evaporated to a gum. Pyridine (10 ml.) and dimethylformamide (1 ml.) were readed and evaporation was repeated until only 1.0 g. of solvent remained. DCC (400 mg.) in pyridine (0.5 ml.) was added under agitation to the mixture, at which point a gum precipitated immediately. One-half of the solvent was removed at room temperature by evaporation under reduced pressure, and the reaction mixture was kept at room temperature. After 12 hr., the reaction mixture was homogeneous except for the ion-exchange resin. A further amount of DCC (250 mg.) was added and the reaction mixture, which was still clear, was kept at room temperature for 5 days. Water (5 ml.) was then added, dicyclohexylurea and excess of DCC being removed in the usual manner. The product was rendered anhydrous by coevaporation with pyridine (four 10-ml. portions) and was kept in a mixture of pyridine (5 ml.) and acetic anhydride (2 ml.). After 2 days, water (10 ml.) was added with cooling, and the resulting solution was extracted with ether (three 20-ml. portions). The aqueous phase was applied to the top of DEAE-cellulose (bicarbonate form) column (40 × 5 cm.). Elution was carried out at 4° with a linear salt gradient (2 l. of 0.05 M triethylammonium bicarbonate in the mixing vessel and an equal volume of 0.3 M triethylammonium bicarbonate in the reservoir). The first 50 fractions eluted 420 O.D.₂₈₀ units of material which contained several unidentified compounds. Fractions 50–100 contained 2800 O.D.₂₈₀ units of ultraviolet-absorbing material (salt concentration at this point 0.14 M) which was composed of the cyclic dinucleotide cyclo-d-pApG (80%) and the dinucleotide d-pApG (20%). The separation after this peak was poor and all of the nucleotidic material corresponding to higher oligonucleotides (3100 O.D.₂₈₀ units) was brought off the column with 1 M triethylammonium bicarbonate. This fraction was concentrated to a gum and was rendered anhydrous by coevaporation with pyridine. Pyridine (2 ml.) and benzoic anhydride (450 mg.) were added and mixture was left for 24 hr. at room temperature. Water (5 ml.) was then added, and pyridinium benzoate and benzoic anhydride were extracted with ether (two 20-ml. portions). The aqueous pyridine phase was treated with 2 N sodium hydroxide (5 ml.) at 0° for 10 min. Sodium ions were removed in the usual way and the resulting aqueous pyridine solution of nucleotidic material was concentrated to a gum. This was dissolved in concentrated aqueous ammonia (20 ml.) and the sealed solution was kept at room temperature. After 2 days the ammonia was evaporated and the bulk of the product was applied in 10 ml. of 95% aqueous pyridine to the top of a DEAE-cellulose (chloride) column (40 × 2.0 cm.) and eluted with a linear gradient of sodium chloride in 7 M urea (4 l. of 0.025 M sodium chloride + 7 M urea in the mixing vessel and an equal volume of 0.25 M salt + 7 M urea in the reservoir). Fractions of 10 ml. were collected every 10 min. The elution pattern obtained is shown in Figure 4 and the distribution of the nucleotidic material is given in Table X.

(34) The R_f , relative to pT, of thymidyl-(3'→5')-deoxycytidine in solvent A was 3.1.

For further purification the products in the main peaks were chromatographed in solvent E. The main bands obtained in this solvent were eluted and were rechromatographed in solvent D. The major bands thus obtained were pure.

Polymerization of a Mixture of 5'-O-Phosphoryl-N⁶-isoyldeoxycytidylyl-(3'→5')-N-benzoyldeoxyadenosine (d-pC^{An}pA^{Bz}) and the Corresponding 3'-O-Acetyl Derivative (d-pC^{An}pA^{Bz}-OAc). To an anhydrous mixture of pyridinium d-pC^{An}pA^{Bz} (3065 O.D.₃₀₂ units, ~0.1 mmole), pyridinium d-pC^{An}pA^{Bz}-OAc (1410 O.D.₃₀₂ units, ~0.046 mmole), and pyridinium Dowex 50 ion-exchange resin (0.1 g.) in dry pyridine (0.5 ml.) was added dropwise a solution of DCC (0.2 g.) in pyridine (0.5 ml.) under exclusion of moisture. The solution was homogeneous during the addition (10 min.) of the first half of the carbodiimide solution while during the addition of the rest of the solution a gummy precipitate separated. The mixture was shaken for 0.5 hr. and the mixture was evaporated *in vacuo* until only about 0.5 ml. of pyridine remained. The stoppered mixture was kept for 30 hr. in the dark and was then treated with 0.5 ml. of 50% aqueous pyridine. After extraction of unreacted DCC with cyclohexane, the aqueous pyridine solution was kept at room temperature. After 12 hr., dicyclohexylurea and resin were removed by filtration and the filtrate was rendered anhydrous by evaporation of added pyridine. The anhydrous residue was dissolved in pyridine (1 ml.) and the solution was treated with acetic anhydride (0.8 ml.) at room temperature for 24 hr. Water (1 ml.) was then added and the mixture was kept at room temperature for 4 hr. The solution was evaporated, rendered anhydrous, and dissolved in pyridine (2 ml.). This solution was added dropwise to an excess of anhydrous ether and the precipitate was treated with concentrated ammonia (2 ml.) in pyridine (1 ml.) for 40 hr.

Separation and Purification of Deoxyribopolynucleotides Containing Alternating Deoxycytidylate and Deoxyadenylate Units. The total polymeric mixture obtained in the preceding experiment was applied on 10 strips (9 in. wide each) of Whatman No. 40 paper, and the strips were irrigated with solvent D (descending technique) for about 30 hr. Major bands detected, in order of decreasing mobility, were as follows: cyclo-d-pCpA, d-pCpA, d-pCpApCpA, d-pC-(pApC)₂pA, d-pC-(pApC)₃pA, and faint bands corresponding to d-pC-(pApC)₄pA and d-pC-(pApC)₅pA. The relative concentrations of these products as determined by elution and spectrophotometric estimation are given in Table XV.

The cyclic dinucleotide cyclo-d-pCpA and the dinucleotide d-pCpA were pure as obtained above. The tetra- and higher polynucleotides were purified further by treatment with bacterial alkaline phosphatase

and subsequent preparative chromatography. Thus, the tetranucleotide d-pCpApCpA and the hexanucleotide d-pCpApCpApCpA were treated with the phosphomonoesterase and the products were chromatographed in solvent D. The major bands thus obtained (R_f values given in Table XVI) were further purified by chromatography in solvent E.

When the octanucleotide d-pC(pApC)₃pA band was treated with bacterial alkaline phosphatase and the product chromatographed for 3 days in solvent D, the major band thus obtained was pure as judged by further chromatography in solvent E.

The faint bands, close to the origin and incompletely resolved, corresponded to d-pC(pApC)₄pA and the dodecanucleotide d-pC(pApC)₅pA. The bands were eluted together and treated with the phosphomonoesterase and the products separated by rechromatography in solvent D for 2 days. The two clearly resolved bands, with increased R_f values (Table XVI) were assumed to be pure.

Characterization of the Hexanucleotide d-pC(pApC)₂pA. A portion of this product was treated with bacterial alkaline phosphatase, and the resulting product, d-C-(pApC)₂pA, (6 O.D.₂₆₀ units) was incubated with purified venom phosphodiesterase. The products, which were separated by paper chromatography in solvent G, were found to be deoxycytidine, deoxycytidine 5'-phosphate, and deoxyadenosine 5'-phosphate. Their relative concentrations were 1:2.2:3.2 (theoretical, 1:2:3).

1-(2'-Deoxy-D-threo-pentofuranosyl)cytosine. 5'-O-Monomethoxytrityl-N-benzoyldeoxycytidine (61 mg., 0.1 mmole) in pyridine (0.8 ml.) was allowed to react with methanesulfonyl chloride (11 mg., 0.1 mmole) at 4° for 16 hr. Ethanol (0.1 ml.) was then added and the mixture was set aside for 2 hr. at 4°. After removal of the solvent by evaporation, the residue was triturated with water and the precipitate collected by filtration, the white solid being washed with water repeatedly. A portion (6 mg.) of the mesyl ester was dissolved in 0.2 ml. of ethanol, 1 *N* sodium hydroxide (0.02 ml.) was added, and the mixture was heated 1 hr. at 80° in a sealed tube. The absorption spectrum showed λ_{\max} 310 m μ with a shoulder at 260 m μ . More sodium hydroxide (0.02 ml. of 1 *N*) was added and the mixture was heated further at 80° for 4 hr. The ultraviolet absorption spectrum taken in ethyl alcohol now showed λ_{\max} 270 m μ . Ethanol was evaporated and the residue was washed with water twice and then dissolved in 80% acetic acid (0.5 ml.). After 8 hr. at room temperature the solvent was removed by evaporation and monomethoxytritanol was extracted by ether. The residue had ultraviolet absorption characteristics: at pH 7.0, λ_{\max} 271 m μ , λ_{\min} 250 m μ ; in 0.02 *N* HCl, λ_{\max} 280 m μ , λ_{\min} 241 m μ ; mobility in paper electrophoresis at pH 6.0 (0.05 *M* sodium borate),²⁹ 1.5 hr. at 15 v./cm., was 1.6 cm. at 4°; that of deoxycytidine was nil.